



National
Defence

Défense
nationale

A-CR-CCP-913/PW-001



Canadian Cadet Organizations

Pipe Band – Snare Drum Reference Manual



Chapter 2

Snare Drum – Level Two

Chapter 2 – Table of Contents

	Tempo (BPM)	Page
Section 1 Technique Exercises		
Single Strokes	120	2-1-1
Double Strokes	96	2-1-2
Flams	96	2-1-3
Drags	96	2-1-4
Paradiddles	96	2-1-5
Quick March Attack Rolls	96	2-1-6
Slow March Attack Rolls	48	2-1-7
Section 2 Repertoire		
Mairi's Wedding	96	2-2-1
The Green Hills of Tyrol – Elementary	96	2-2-2
When the Battle's O'er – Elementary	96	2-2-3
Scotland The Brave – Elementary	96	2-2-4
The Bluebells of Scotland	96	2-2-5
The Nut Brown Maiden	96	2-2-6
Will Ye No Come Back Again – Elementary	96	2-2-7
The Quaker's Wife – Elementary	96	2-2-8
The Steamboat	96	2-2-9
The Skye Boat Song – Elementary	48	2-2-10
Going Home – Elementary	48	2-2-11
Scotland the Brave (Advance in Review Order)	96	2-2-12
The Maple Leaf Forever (General Salute)	96	2-2-12



**C
H
A
P
T
E
R

2**

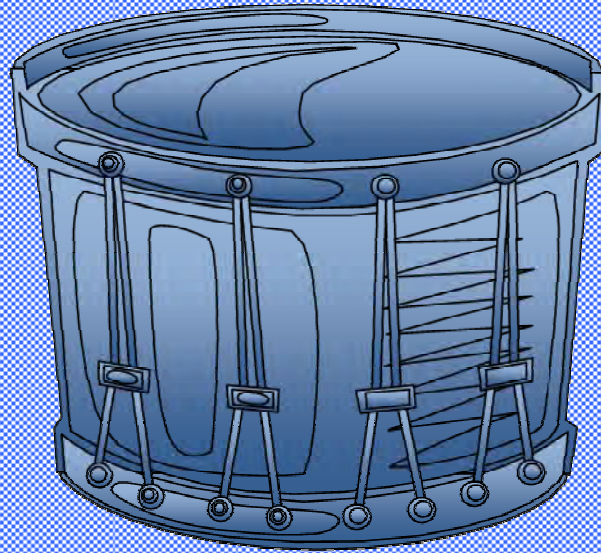



Section 1

Technique Exercises





Single Strokes

1 $\frac{2}{4}$ 

2 $\frac{2}{4}$ 

3 $\frac{2}{4}$ 

4 $\frac{2}{4}$ 

5 $\frac{2}{4}$ 

6 $\frac{6}{8}$ 

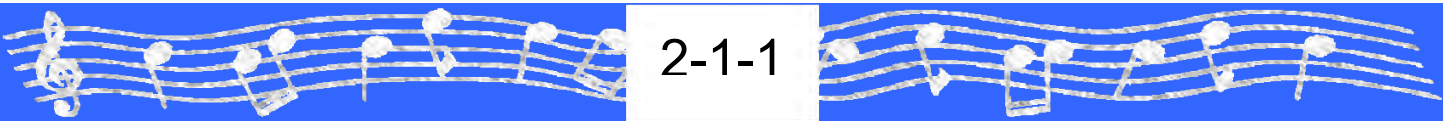

Double Strokes

7 $\frac{2}{4}$

8 $\frac{2}{4}$

9 $\frac{2}{4}$

10 $\frac{2}{4}$

11 $\frac{2}{4}$

12 $\frac{2}{4}$

13 $\frac{2}{4}$

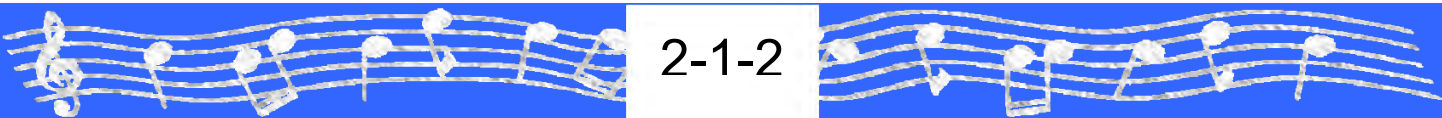

Flams

14 $\frac{2}{4}$ 

15 $\frac{4}{4}$ 

16 $\frac{2}{4}$ 

17 $\frac{2}{4}$ 

18 $\frac{2}{4}$ 

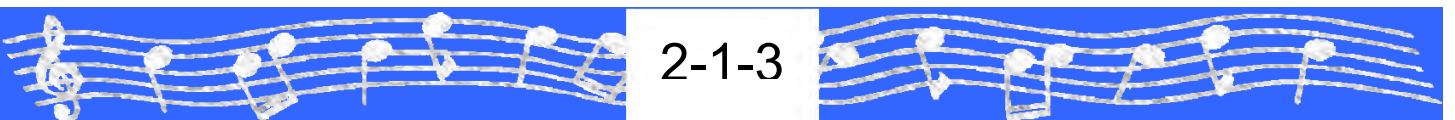

Drags



- A drag is an embellishment similar to a flam.
- **Right Drag:** A buzz on the right hand followed by a main stroke on the left hand.
- **Left Drag:** A buzz on the left hand followed by a main stroke on the right hand.

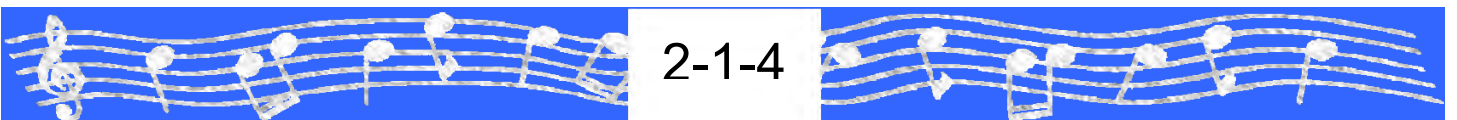

Paradiddles

21 $\frac{2}{4}$

22

23

24

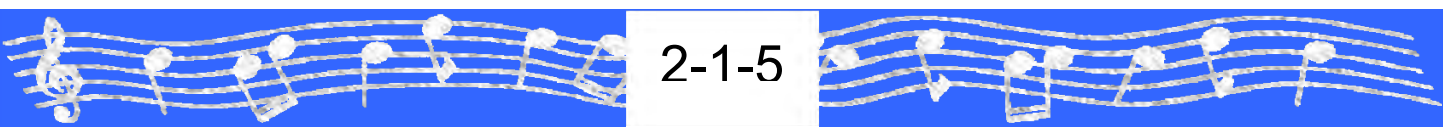

Attack Rolls

25 Quick March Attack

The musical score is written for four parts: Tenor Drum, Bass Drum, Snare Drum, and Bagpipes, all in 4/4 time. The score is divided into three sections by vertical lines:

- Word of Command:** The Tenor Drum part has the text "Rolls.....Quick March" written below it. All parts play a series of rhythmic strokes.
- Rolls:** The Tenor Drum part has three circled 'X' marks above it. The Bagpipes part has the instruction "Hand up to Bag" written above it. The Tenor Drum part has the text "Drones.....'E'" written below it.
- Start of Tune:** The Tenor Drum part has two circled 'X' marks above it. The Bagpipes part begins with a melodic line.

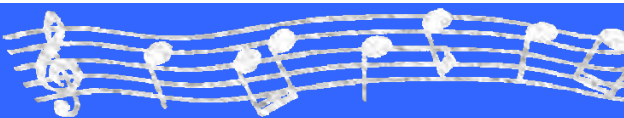

2-1-6



Attack Rolls

26 Slow March Attack

The musical score is divided into three sections: **Word of Command**, **Rolls**, and **Start of Tune**.

Word of Command: The Tenor Drum, Bass Drum, and Snare Drum play a rhythmic pattern of quarter notes. The Bagpipes play a single note with the instruction "Hand up to Bag".

Rolls: The Tenor Drum plays three notes with a circled 'X' above each. The Bass Drum plays three notes. The Snare Drum plays three notes with a slur over the first two. The Bagpipes play three notes with the instruction "Drones.....'E'".

Start of Tune: The Tenor Drum and Bass Drum play two notes with a circled 'X' above each. The Snare Drum plays a sequence of notes with a slur and a '7' indicating a grace note. The Bagpipes play a sequence of notes.

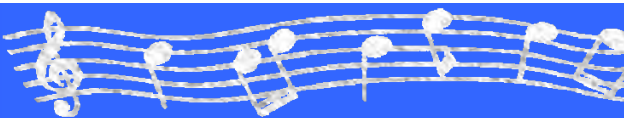

2-1-7



C
H
A
P
T
E
R

2

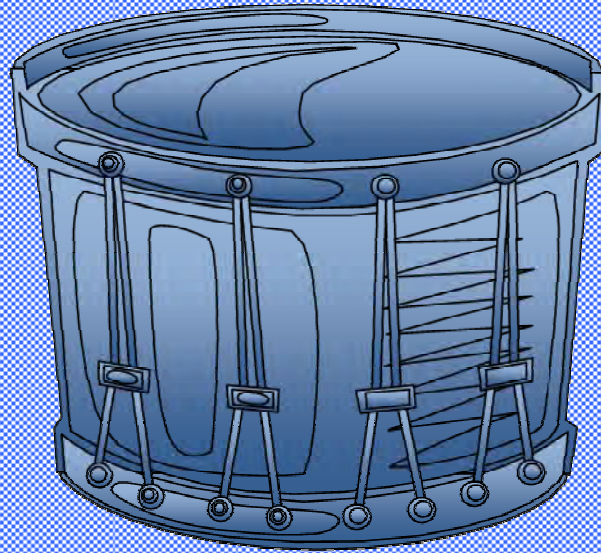

Section 2

Repertoire



Mairi's Wedding

March

The musical score is written in 2/4 time and consists of four staves. The first staff begins with a treble clef, a key signature of one flat (B-flat), and a common time signature of 2/4. The melody is characterized by eighth-note patterns and rests, with some notes beamed together. The second and fourth staves end with repeat signs. The third staff begins with a double bar line and a repeat sign, indicating a second ending or a specific section of the piece.

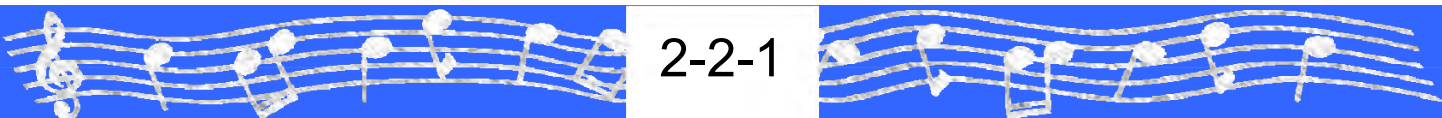

The Green Hills of Tyrol

Retreat March
Elementary

The musical score is written on four staves in treble clef with a 3/4 time signature. The first staff begins with a repeat sign. The melody consists of eighth and quarter notes, with several triplet markings (indicated by a '3' above a bracket) and slurs. The second and fourth staves end with double bar lines and repeat dots. The third staff also begins with a repeat sign.

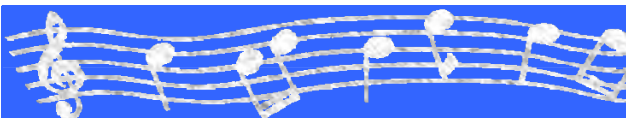

2-2-2



When The Battle's O'er

Retreat March
Elementary

Musical score for 'Retreat March' in 3/4 time, elementary level. The score consists of four staves of music. The first staff begins with a treble clef, a 3/4 time signature, and a repeat sign. The melody features eighth and sixteenth notes, with some triplets indicated by a '3' above a bracket. The second staff continues the melody with similar rhythmic patterns and triplets. The third and fourth staves also follow the same melodic line, ending with repeat signs. The key signature is one sharp (F#).



2-2-3



Scotland The Brave

March
Elementary

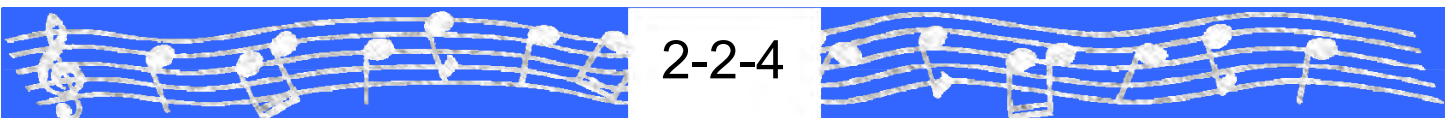

The Bluebells of Scotland

March

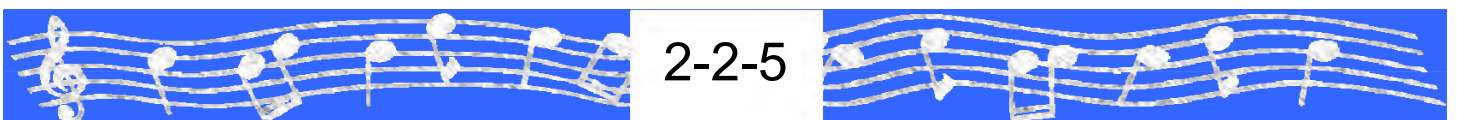

The Nut Brown Maiden

March

The image displays two staves of musical notation for the march 'The Nut Brown Maiden'. The top staff begins with a treble clef and a 4/4 time signature. The music consists of a series of eighth and sixteenth notes, with some notes beamed together. The bottom staff continues the melody, featuring similar rhythmic patterns and some rests. Both staves end with a double bar line and repeat dots.

A decorative footer consisting of a blue horizontal bar. On the left and right sides of the bar are stylized musical notes and stems. In the center of the bar, the text '2-2-6' is written in a white, sans-serif font.

Will Ye No Come Back Again

March
Elementary

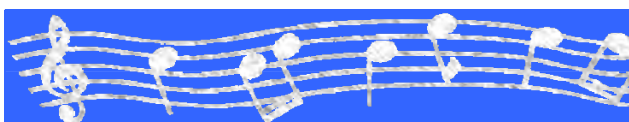

2-2-7



The Quaker's Wife

March
Elementary

The musical score is written for a single melodic line in 6/8 time. It consists of four staves of music. The first staff begins with a treble clef, a key signature of one flat (B-flat), and a 6/8 time signature. The melody starts with a quarter rest, followed by a quarter note G4, a quarter note F4, and a quarter note E4. The second staff continues the melody with a quarter note D4, a quarter note C4, and a quarter note B3. The third staff features a quarter note A3, a quarter note G3, and a quarter note F3. The fourth staff concludes the piece with a quarter note E3, a quarter note D3, and a quarter note C3. The score includes various musical notations such as beams, slurs, and a triplet of eighth notes in the second staff. The piece ends with a double bar line and repeat dots.

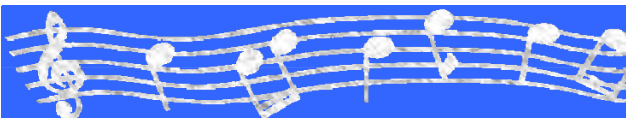

2-2-8



The Steamboat

March

The musical score for 'The Steamboat' is written in 2/4 time and consists of four staves. The first staff begins with a treble clef, a key signature of one flat (B-flat), and a common time signature (C). The melody is characterized by a steady eighth-note rhythm with frequent beamed eighth notes. The first two staves each contain two measures, and the last two staves each contain two measures. The piece concludes with a double bar line and repeat dots. The notation includes various note values, rests, and phrasing slurs.

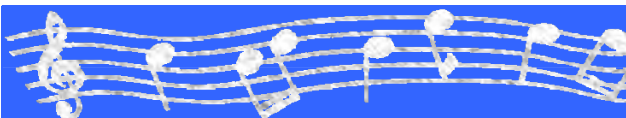

2-2-9



The Skye Boat Song

Slow March
Elementary

The musical score for 'The Skye Boat Song' is presented in four staves. The first staff begins with a treble clef, a 6/8 time signature, and a key signature of one flat (B-flat). The melody is written in a simple, accessible style suitable for elementary school students. It features a series of eighth and quarter notes, often beamed together, with some notes tied across bar lines. The piece concludes with a double bar line and repeat dots. The second and fourth staves are identical to the first and third staves, respectively, indicating a two-measure repeat structure.

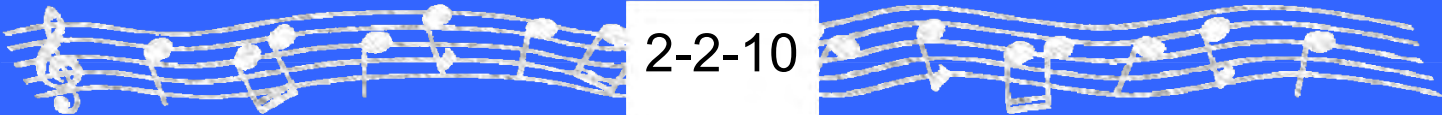

Going Home

Slow March
Elementary

The musical score for 'Going Home' is presented in four staves. The first staff begins with a treble clef, a 6/8 time signature, and a key signature of one flat (B-flat). The melody consists of eighth and quarter notes, with some notes beamed together. The second staff continues the melody, ending with a double bar line and repeat dots. The third staff shows the bass line, featuring a series of chords and single notes, with two slanted lines indicating dynamics. The fourth staff continues the bass line, also ending with a double bar line and repeat dots.

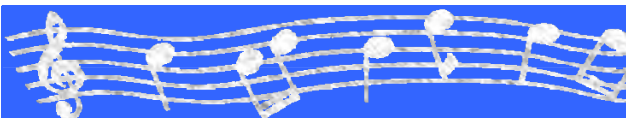

2-2-11



The Advance and General Salute

Advance

Scotland The Brave

Arr: Maj A.M. Cairns MMM CD

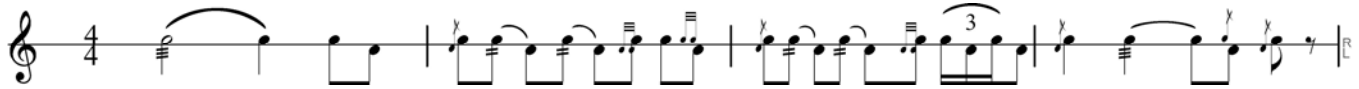

General Salute

The Maple Leaf Forever

Arr: Maj A.M. Cairns MMM CD

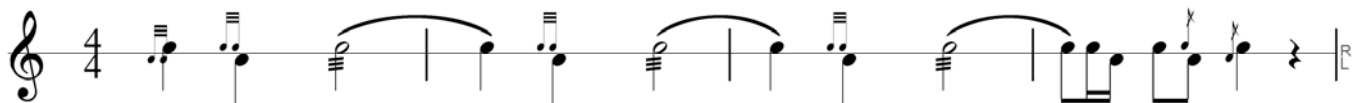

There are three salutes used within the Canadian Forces and Canadian Cadet Organization, the Royal Salute*, the Royal (Vice-Regal) Salute** and the General Salute. The following table illustrates the use of these salutes based on the status of the dignitary being honoured.

*Note: The Royal Salute is covered in Level 4. **Note: The Royal (Vice-Regal) Salute is covered in Level 3.

Royal Salute (Mallorca)

- HM the Queen
- Members of the Royal Family
- Foreign Sovereigns
- Members of Reining Foreign Families
- Heads of State
- Governor General of Commonwealth Countries.

Royal (Vice-Regal) Salute (Mallorca / O' Canada)

- Governor General of Canada
- Lieutenant Governor of a Canadian Province

General Salute (Maple Leaf Forever)

- Prime Minister of Canada
- Premiers of Canadian Provinces
- Members of Parliament (provincial or federal)
- Municipal Politicians
- Military Officers (major and above)
- Distinguished Persons



2-2-12

