



National  
Defence

Défense  
nationale

A-CR-CCP-913/PW-001



# Canadian Cadet Organizations

## Pipe Band – Snare Drum Reference Manual

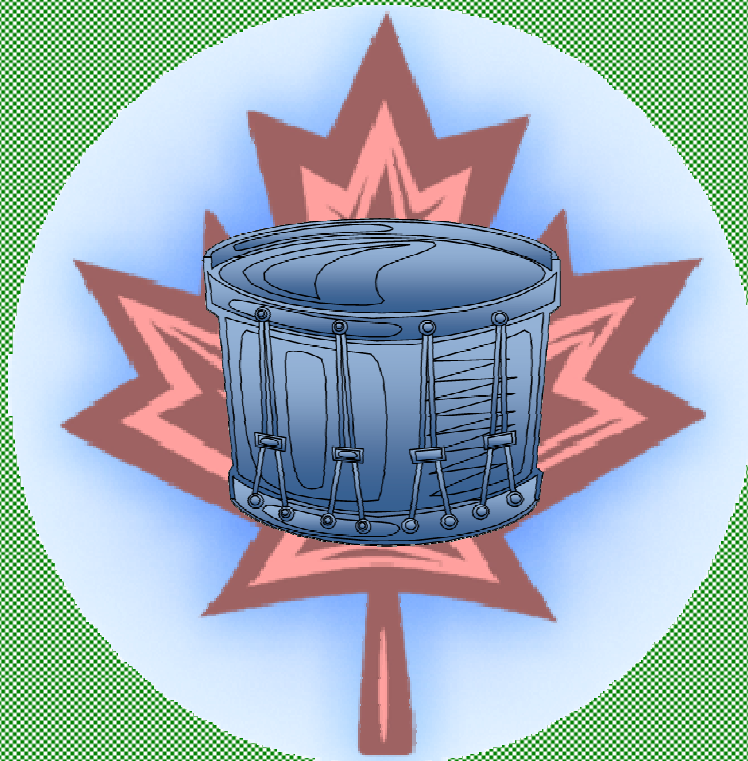

### Chapter 1

## Snare Drum – Level One



Canada 

# Chapter 1 – Table of Contents

	Tempo (BPM)	Page
<b>Section 1 Technique Exercises</b>		
Single Strokes	96	1-1-1
Double Strokes	96	1-1-2
Flams	90	1-1-3
Triplets	96	1-1-4
Paradiddles	90	1-1-5
Buzz Stroke Introduction	90	1-1-7
<b>Section 2 Repertoire</b>		
Mairi's Wedding - Étude	96	1-2-1
The Green Hills of Tyrol – Étude	96	1-2-2
Scotland The Brave – Étude	96	1-2-3
The Nut Brown Maiden – Étude	96	1-2-4
The Fairy Lullaby – Étude	48	1-2-5
The Song of the Glen – Étude	48	1-2-6



1-1



**C  
H  
A  
P  
T  
E  
R  
  
1**

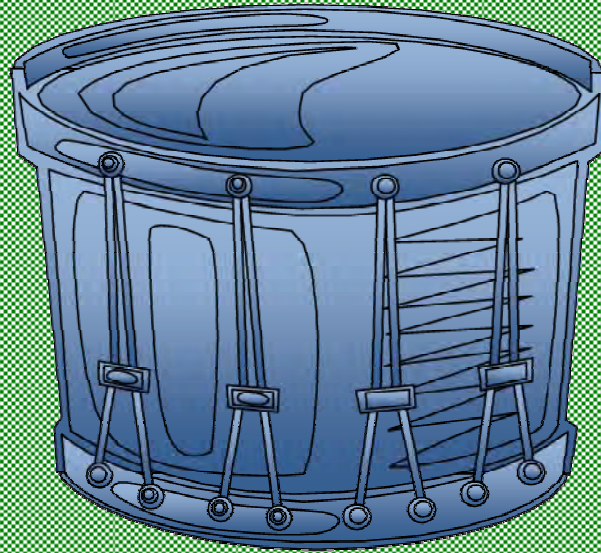

# **Section 1**

## **Technique Exercises**



# Single Strokes

1  $\frac{2}{4}$  ||:  :||

2  $\frac{2}{4}$  ||:  :||

3  $\frac{4}{4}$  ||:  :||

4  $\frac{6}{8}$  ||:  :||



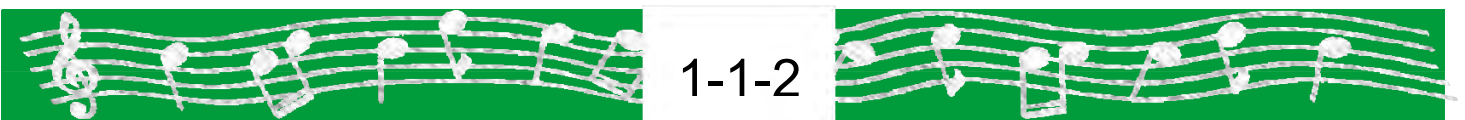
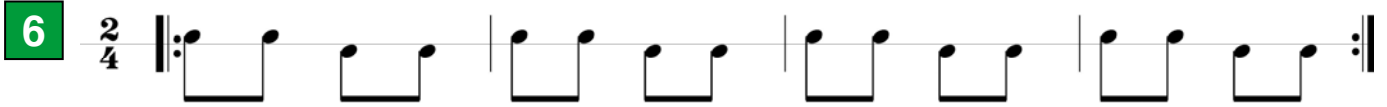

# Double Strokes



# Flams

7  $\frac{2}{4}$  ||:  :||

8  $\frac{2}{4}$  ||:  :||

9  $\frac{2}{4}$  ||:  :||

10  $\frac{2}{4}$  ||:  :||

- To play the flam, two strokes are played closely together with a small separation.
- They must strike close enough to almost sound like one stroke.
- A flam is a type of grace note or embellishment. In pipe band music the grace note has three purposes: To separate two notes, to accent a specific note, and to embellish a specific note.

## Right Flam



- When playing a right flam, hold the right stick slightly higher.

## Left Flam



- When playing a left flam, hold the left stick slightly higher.



1-1-3



# Triplets

**11** 

**12** 

**13** 

**14** 

**15** 

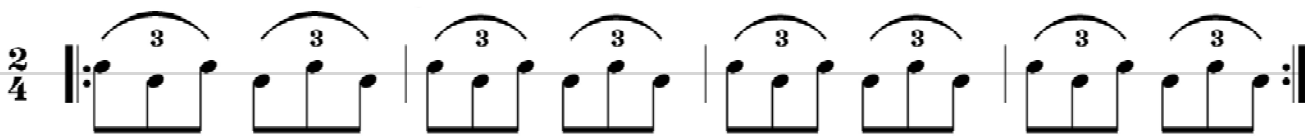
**16** 

- A triplet is not a rudiment, it is a rhythm.
- A triplet is three notes played in the same time as two notes of the same duration.

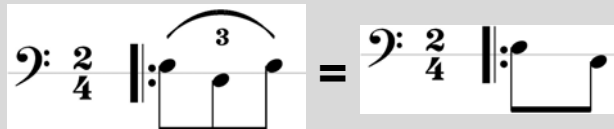

1-1-4



# Paradiddles



- The paradiddle rudiment consists of three strokes, two single strokes and one double stroke.
- Each stroke should have the same volume and be the same weight.



1-1-5





# Paradiddles

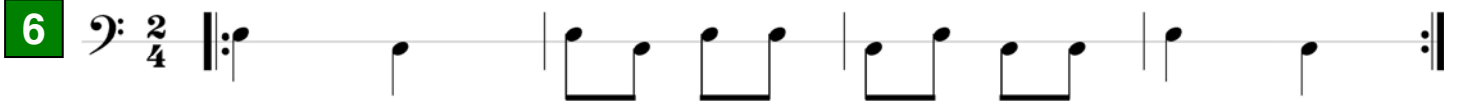

1-1-6



# Buzz Stroke Introduction

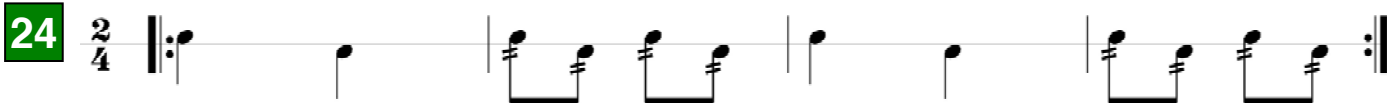
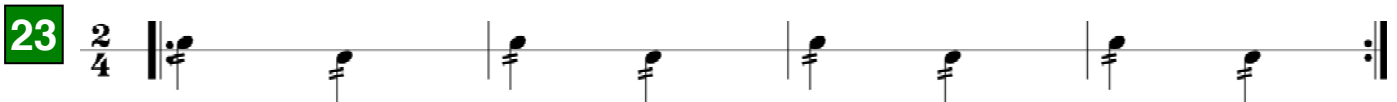

- The buzz stroke consists of a “Buzz” of two single strokes.
- The buzz sound occurs when the drumstick bounces slight when striking the drum.



1-1-7



# Buzz Stroke Introduction

**6**

**7**

**8**

**9**

**10**



1-1-8



# Buzz Stroke Introduction

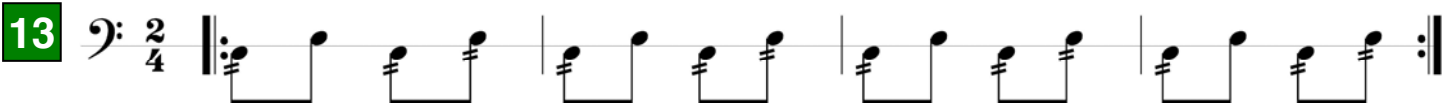
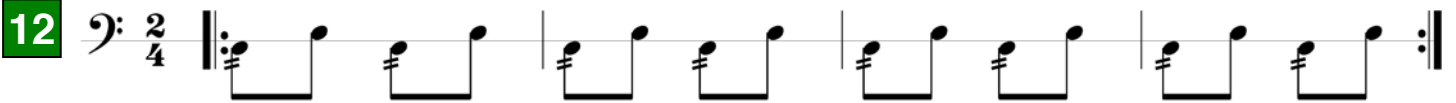
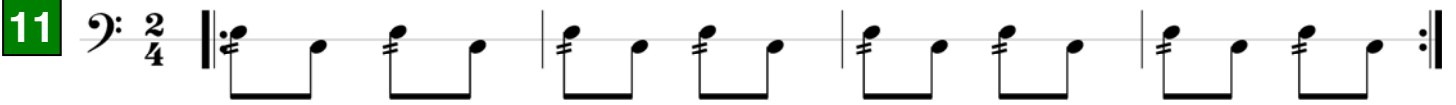

1-1-9



**C  
H  
A  
P  
T  
E  
R  
  
1**

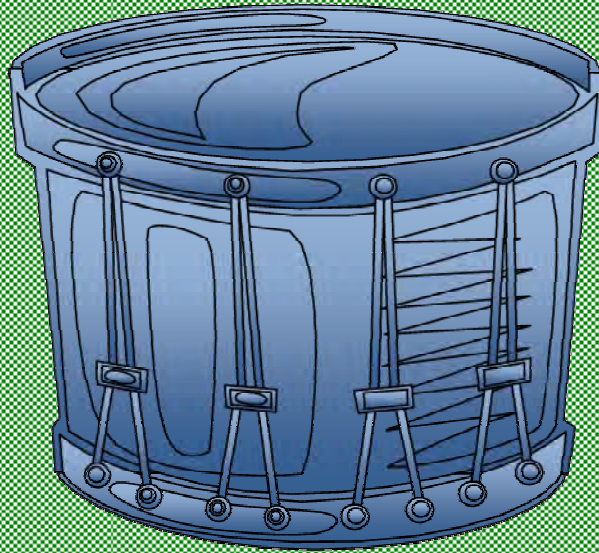

# **Section 2**

## **Repertoire**



# Mairi's Wedding

March  
Étude

The musical score is written in 2/4 time on a single treble clef staff. It begins with a key signature of one flat (B-flat) and a repeat sign. The first line contains four measures: the first three have accents over the first notes, and the fourth ends with a repeat sign. The second line contains four measures, with the first three having accents and the fourth ending with a double bar line and repeat dots. The third line contains four measures, all ending with repeat dots. The fourth line contains four measures, with the first three having accents and the fourth ending with a double bar line and repeat dots.

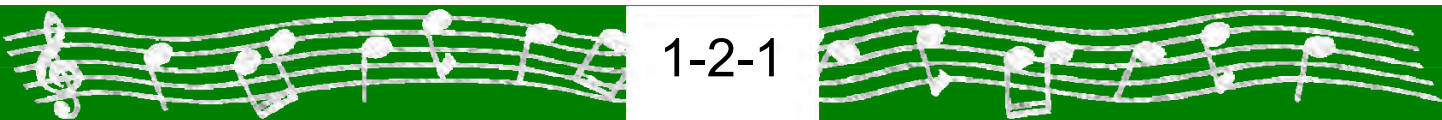

# The Green Hills of Tyrol

Retreat March  
Étude

The musical score is written on four staves. The first staff begins with a treble clef, a 3/4 time signature, and a key signature of one flat (B-flat). The melody starts with a repeat sign. The first two measures of the first staff contain eighth notes and a quarter note. The next two measures feature a triplet of eighth notes. This pattern of eighth notes and triplet eighth notes continues throughout the piece. The score concludes with a double bar line and repeat dots.



1-2-2



# Scotland The Brave

March  
Étude

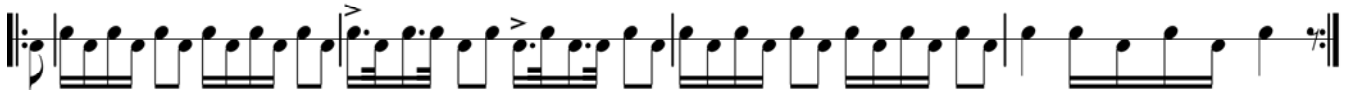

1-2-3





# The Nut Brown Maiden

March  
Elementary

Musical score for 'The Nut Brown Maiden' in 4/4 time. The score consists of two staves. The first staff is in treble clef and the second staff is in bass clef. Both staves begin with a repeat sign. The melody is composed of quarter and eighth notes, with some sixteenth-note runs. The piece concludes with a double bar line and repeat dots.

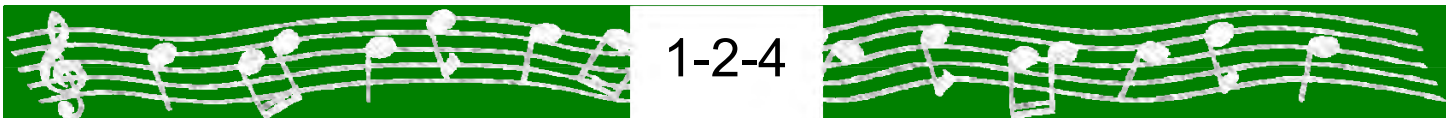

# The Fairy Lullaby

Slow March



1-2-5



# The Song of The Glen

Slow March  
Étude

Musical score for 'The Song of The Glen' in 6/8 time, featuring a slow march and étude. The score consists of four staves of music. The first staff begins with a treble clef, a 6/8 time signature, and a repeat sign. The music is written in a single melodic line. The second staff continues the melody. The third staff begins with a repeat sign and includes several triplet markings (indicated by a '3' above a bracket). The fourth staff concludes the piece with a repeat sign and a double bar line.

